

BONT[®]

Bont Technologies GmbH

2 WIRE ULTRASONIC TRANSMITTER UT1000-3



Working Principle

Based on the principle that sound measured the distance. when the ultrasonic pulse radiated by the probe meets the surface of the medium measured, it will be reflected into four waves. Then the probe will receive the reflected wave and the time difference will be calculated through circuit analysis and transformed into electrical signal, in this way, the distance between the probe and medium measured (the height of the medium) will be calculated.

Technical Paramters

Measure Range	0 ~ 15m (Based on the selected range)	Output	4 ~ 20mA
Dead Zone	0.25m ~ 0.6m	Digital Output	RS485, MODBUS protocol or custom protocol
Accuracy	0.3% (Standard Condition)	Power Supply	DC24V/AC220V, (Built-in Lightning protection device)
Resolution of Range	1 mm	Environment Temperature	-20°C ~ 60°C
Pressure	Under 4 unit Standard atmospheric pressure	IP Grade	IP65
Display	LCD display level or space distance		

Installation

Instrument size (probe size will change along with the different measuring range of the instrument).

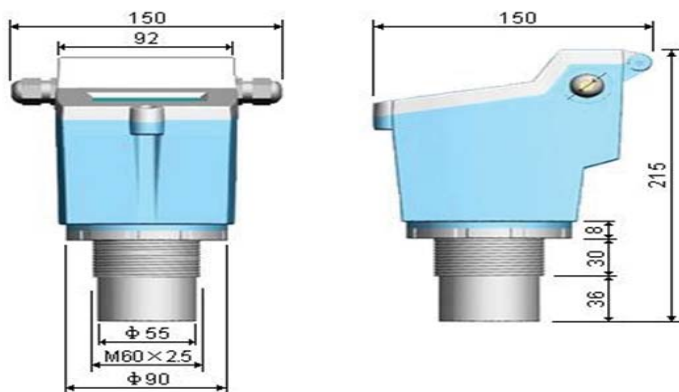

Installation Method

For open environment generally using support installation, fixed by flange which on the instrument. For the pool or tank, cut a round hole (slightly bigger than probe diameter (60mm) in the installation position, then put the probe into the hole, then tightening the flange. During the installation must ensure that the probe surface and measured surface are in the same level.

Installation Parameter

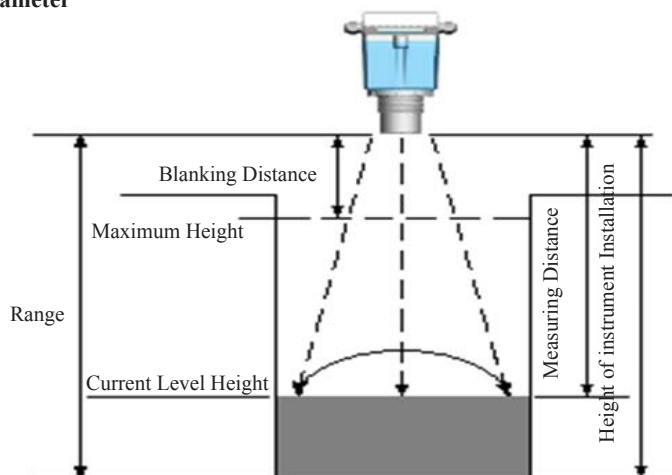

As picture above, the instrument probe send wave hit level then reflected back to probe, after received wave, the probe calculated the time from sending wave to receive, get measuring distance L, the height of instrument installation TH minus the measuring distance L, then will get the current level height H.

Instrument range refers to the distance which the instrument can measure; installation height TH should be less than this range.

Instrument dead zone refers to the area near the probe which the probe can't measure, the distance between the highest liquid level and probe should be greater than dead zone, for example, if the dead zone is 0.3m, the distance between the highest liquid and probe must be greater than 0.3m.

Probe send wave is a diffusion process, there is a Angle Direction, when installation, please pay attention to this, the wave may hit the wall of the tank / container / channel edge and etc.