

180 KW Electric Steam Boiler

TECHNICAL INFORMATION

Model	SB-BT-180KW
Power	180Kw
Rated Evaporation	258kg/hr
Rating current	270A
Working voltage	380V / 50Hz
Operation steam pressure	0.7Mpa
Saturation steam temperature	170°C
Sectional area of power wire	2*70mm ²
Pump Power	0.75Kw / 50Hz
Furnace Wall	8mm
Thermal efficiency	98%
Heating Control	Progressive or PLC
Dimension	1300*1530*2130mm
Package Size	1370*1600*2260mm
Steam pipe diameter	DN32mm
Sewer diameter	DN32mm
Inlet diameter	DN25mm
Safety Valve diameter	DN40mm

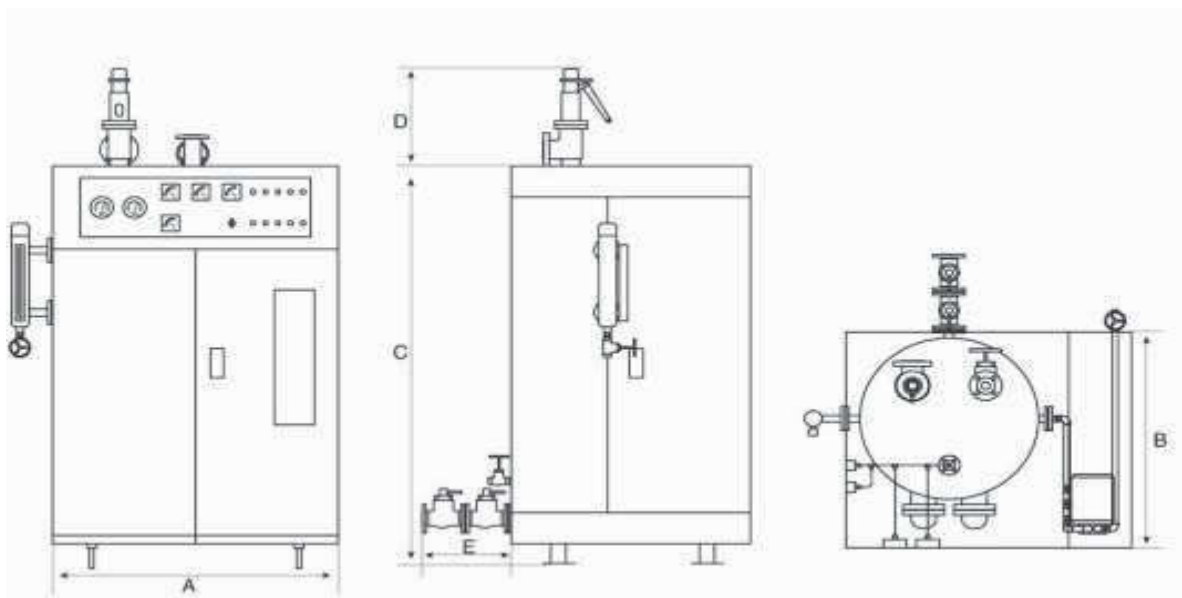

*** This catalogue is for reference only.

*** The boiler room design is subject to principle drawing.